



Northern Virginia Regional Group

www.nvrg.org

Valve Clatter

Early Ford V-8 Club of America



Northern Virginia Regional Group #96
Chartered December 11, 1977

Volume XL, No. 1

January 2018

Stephanie Beavers - Editor

2017 NVRG Holiday Gala Party

By Joe Freund

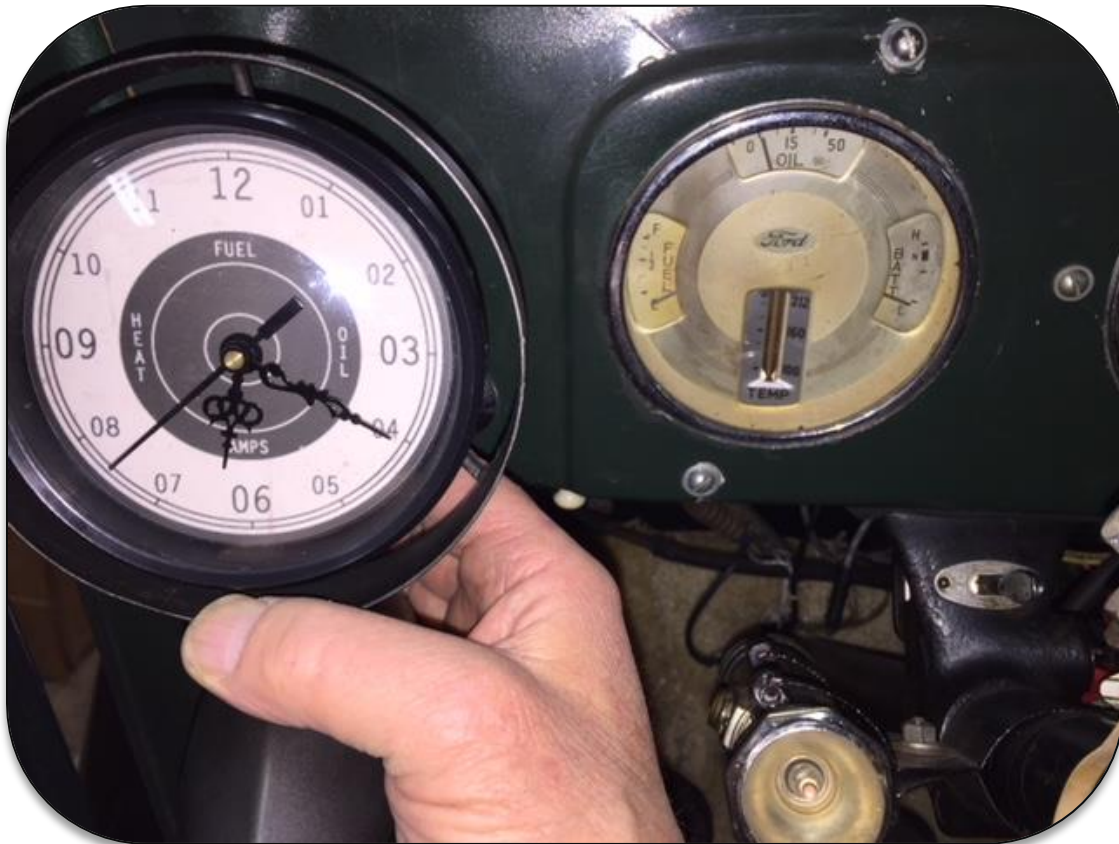

Picture of Clem's Clock

We held our annual NVRG Holiday Gala at P.J. Skidoos in Fairfax on Saturday, December 9. Despite several inches of snow that afternoon we had a great turnout of 43 people. The theme for this year's holiday gala was celebrating our club's 40th Anniversary. In recognition of this special milestone, five of the six charter members who founded our club were able to attend including **Hank Amster, Nick Arrington, Mike Gall, Cliff Green** and **Bill Selley**. **Clift Hardin** was unable to join us. Each of the six charter members were awarded with a 40th anniversary plaque with their names inscribed, recognizing them for their foresight and many years of tireless and dedicated service to the club.

Up Front with the President

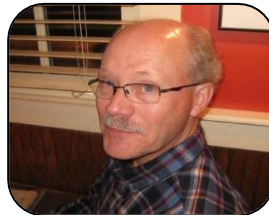

January 2018

2017 was a terrific year for our antique Ford car club! We had several high-profile milestones which I would like to cover in a retrospective of 2017.

Without a doubt the Eastern National Meet tops the chart. Under the leadership of **Bill Simons** and his attention to a detailed planning process, many club members volunteered to lead segments of the meet including registering guests; selecting and assembling goody bags; collecting items, setting up and running the highly lucrative raffle room; planning and leading tours; judging the cars on the concourse; overseeing the swap meet; working with the hotel staff on food and venues; planning the Cross Farm Picnic; and trailer parking. All involved a high degree of preparation, membership involvement and execution to truly say that the 2017 Eastern National Meet was a great success. To top it off, we had a high national membership turnout, perfect weather, and an excellent location at the Westfields Marriott, Chantilly, Virginia.

Our club celebrated the 20th anniversary of co-hosting the City of Fairfax Antique Car Show. Amazingly we have been very fortunate to have **Dave Westrate** at the helm for 20 years! Dave has so fine-tuned the process that it's almost on auto pilot. Imagine, only once in 20 years the weather did not cooperate.

Starting my third year as president, I have been very fortunate to have the support and wisdom of a very qualified board of directors. Past presidents, a charter member and long-standing board members have all been willing to help guide and realign me as needed. Even when a family emergency arose this year, board members immediately stepped in to carry on our work without a break in the cadence. **Bill Simons** as vice president kept thing rolling seamlessly.

Membership programs and tour events in 2017 led by **Dave Gunnarson** and **Hank Dubois** were always of high quality and enjoyed by the membership. **Wayne Chadderton** methodically kept our club's finances in order which included his time-consuming duties associated with overseeing all the monies and payments for the Eastern National Meet. The club enjoyed an increase in membership to over 150 under the leadership of **Gay Harrington** who also kept member contact information up-to-date and collected yearly dues. **Cliff Green** and **Jim McDaniel** created our annual club calendar with our members' antique car photos. **John Ryan** as club secretary kept copious notes during our board meetings and ensured the meeting minutes were prepared and issued in a timely manner. **Mark Luposello** kept track of all our club supplies and lined up members to host refreshments/snacks at our monthly meetings. **Cliff Green** maintained and updated the club's website. **Keith Randall** was the point of contact for information about the general welfare of the membership. **Andy Koerner**, **Jim LaBaugh**, **Jim McDaniel**, **John Sweet**, and **Art Zimmerli** served as board members-at-large and pitched in whenever needed on special projects.

2018 NVRG Officers & Terms	2018 Directors & Terms	Committee Members
President – Joe Freund (2018-19)	Membership – Gay Harrington (2018-19)	Fairfax Show – Dave Westrate
Vice President – Bill Simons (2018-19)	Programs Lead – Dave Gunnarson (2017-18)	Programs Member – John Sweet
Secretary – John Ryan (2017-18)	Webmaster – Cliff Green (2018-19)	Tours Chair – Hank Dubois
Treasurer – Wayne Chadderton (2017-18)	Sunshine – Keith Randall (2017-18)	Property & Refreshment – Mark Luposello
	Past President – Jim McDaniel (2018-19)	At Large – Art Zimmerli
	At Large – Ken Burns (2018-19)	At Large – Andy Koerner
		At-Large – Jim LaBaugh

The year concluded with the Annual Holiday Gala on December 9th where we celebrated our 40th Anniversary and recognized our six charter members - **Hank Amster, Nick Arrington, Mike Gall, Cliff Green, Clift Hardin, and Bill Selley**. The President's Special Recognition Awards were presented to **Ken Burns, Bill Simons, and Dave Westrate**. See Holiday Gala article for more details.

Ken Burns was the highly skilled and steadfast editor of this newsletter published monthly for eight years. Imagine, that was 96 consecutive editions! Ken received several national awards during his tenure as editor which serves as a testament to his amazing editing and creative abilities which we already knew. Thanks again, Ken, for your dedication over all those years!

Best Regards,

Joe

Your 2018 dues are due by January 31!



I hope everyone is enjoying the holidays, and here's wishing all our NVRG members near and far a very Happy New Year! If you have already renewed your membership for 2018, **THANK YOU!** If you haven't yet renewed, please remember that 2018 dues are due now, and are still only \$15.00.

Just send your check (**payable to NVRG**) to **Gay Harrington, 3080 N. Quincy Street, Arlington, VA 22207** on or before January 31, 2018, and you will enjoy another year of Ford V8 fun and camaraderie! If you have changes in your information (address, phones, email, vehicles, etc.), please let me know and I'll update your membership information.

Thank you for your membership in the NVRG Chapter 96 of the Early Ford V-8 Club of America!

Looking forward to more V8'ing (and V12'ing, too) with you in 2018,

Gay Harrington, NVRG Membership Chair

Holiday Gala continued from front page.

The club was also very fortunate to benefit from the extra special individual accomplishments of three outstanding club members. As president, I decided to institute a new award called the "President's Special Recognition Award" that future presidents of the club can elect to bestow when major contributions by individuals merit recognition. This year there were three club members that raised the bar for all of us, based on their extraordinary dedication, selfless contributions, and unwavering commitment to make our club an outstanding organization. In alphabetical order, this year's recipients were **Ken Burns as Editor of the Valve Clatter** for eight years, **Bill Simons as Chairman of the 2017 Eastern National Meet**, and **Dave Westrate as Chairman of the City of Fairfax Antique Car Show** for 20 years. We thank them for their leadership and expertise.

After a wonderful dinner and dessert, we transitioned to the gift exchange in which the order is determined by raffle ticket numbers pulled out of the hat. **Bill Simons** as gift exchange master of ceremonies chose the first ticket which matched the ticket held by **Clem Clement**. So, Clem chose the first gift which then led to the following zany account that only Clem can tell:

"At the wonderful eV-8 Christmas party, I was chosen to select a gift first, (which is proper and right.) I wanted to choose the BAR but that was OOB (Out of Bounds). I selected a not-so-small bag which called me. Due to a combo of my exuberance and immaturity, I tossed and threw the wrappings every which way. I've done that since I grew up as well as in childhood. Out came a neat outside-mirror-shaped desk clock. In waving it around the clock part sailed away and bounced once before I retrieved it and placed it back in the mount. Turns out nothing was busted. The clock portion was taped in place by two (only 2) small pieces of duck tape about the size of 1/27th of a postage stamp. For a regular person, the clock needed to be removed to change the battery. Somehow the battery area cov-

er went South for the winter. Makes no matter as the cover only covered the small battery, and was not designed to hold the battery in place. Of course, I hadda make a big fuss and too-do about crawling about searching. Please understand I already knew I was not going to trade off the clock. The clock face was the same as the instrument panel of my '39 Pickup truck. Multiple circular rings and 4 labels: Fuel, amps, oil pressure and temp. Obviously it was meant for me."

"You also know that I can't stay quiet at a "brown bag event." So, all the show and carrying on silliness was vintage me, plus me protecting my clock. It worked. I'm grateful for the gifter's thoughts. The gift will serve me well and it also garnered many a hearty laugh at the fun Christmas party."

NORTHERN VIRGINIA REGIONAL GROUP SPECIAL RECOGNITION



President Joe Freund presents Valve Clatter Editor Ken Burns with the President's Special Recognition Award for 8 years of dedicated service as Editor.



President Joe Freund presents Bill Simons with the President's Special Recognition Award for leading the 2017 Eastern National Meet.

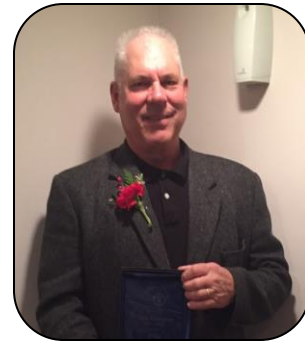

Charter Member Nick Arrington



President Joe Freund presents Dave Westrate with the President's Special Recognition Award for 20 years of leading the City of Fairfax Antique Car Show.



Charter Member Mike Gall

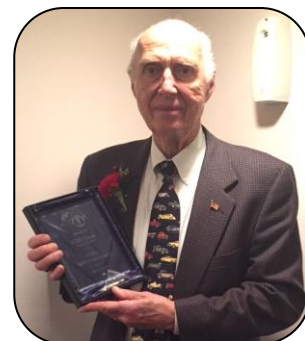

Charter Member Cliff Green

**NORTHERN VIRGINIA REGIONAL GROUP
CHARTER MEMBERS**



Charter Member Hank Amster



Charter Member Bill Selley

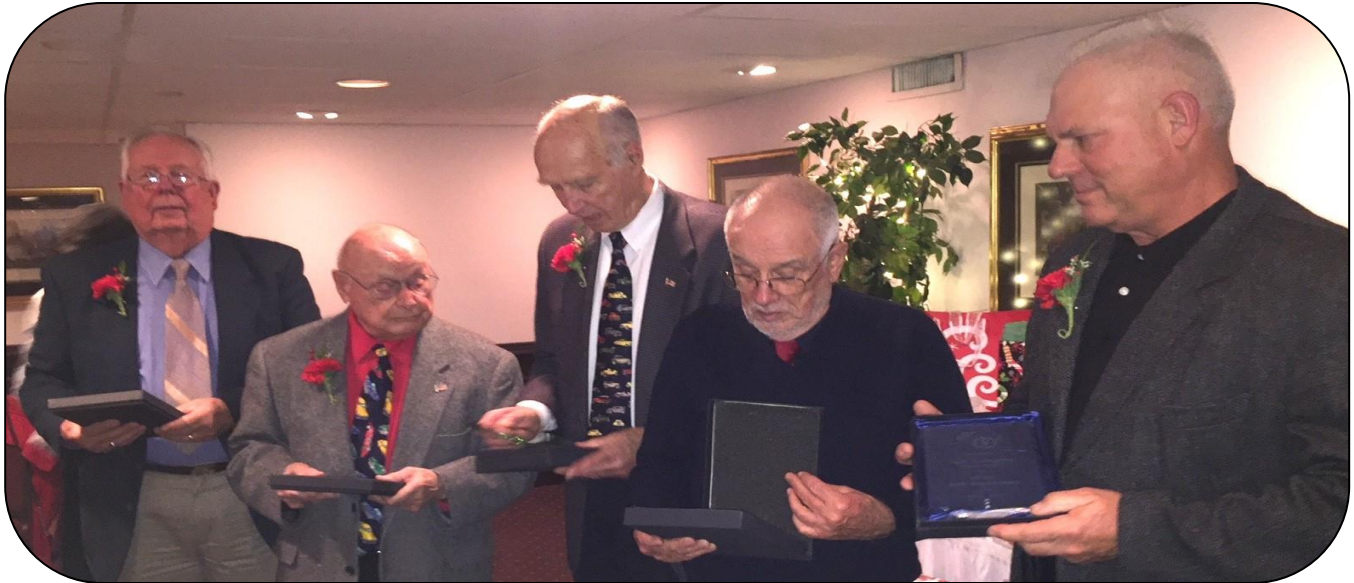

Charter members admiring their plaques presented by President Joe Freund. Left to right: Mike Gall, Hank Amster, Cliff Green, Bill Selley, Nick Arrington.

NVRG TOUR PLANS & IDEAS FOR 2018

As we head into the new year, I'm sure that most of you are like me in looking forward to our Club tours whether they be garage tours during the colder months or road trips during the warmer months when we can get our vintage V-8's (or V-12's, straight 6's or even 4's) out of the garage and use them for what they were designed for – driving! As in past years, our tour schedule for 2018 will be pretty fluid and will develop over the course of the year as ideas and opportunities present themselves. Of course, we will have our three “traditional” tours - Spring Poker Run, late Summer Drive-In Movie Tour, and Fall Tour – and, we've been invited to return to Oatlands Plantation in July for their Third Annual WWI & WWII Weekend. We'll also have a chance to get our cars out for our Club's Summer Picnic as well as some car shows, specifically, our own Fairfax Car Show in May, the Sully Plantation Show in June, and the Clifton (Fairfax) Show in September.

What we need now are some ideas/suggestions for garage (or other interesting) tours especially for the months of January-March and November-December. So, if you have an idea or suggestion for such a tour, please call me at 703-476-6919 or send me an email at handcdubois@verizon.net and give me the details.

Your ideas/suggestions need not be car-related but should, of course, have general appeal to the Club's membership. Additionally, if you have any ideas/suggestions for driving tours, including “flash tours”, I would appreciate hearing from you. Thanks in advance for your input and I look forward to seeing many of you “on tour” this year.

TECH TALK

By Cliff Green

Here is a \$.90 part that will disable your Ford and require a tow. Jim Cross experienced this breakdown returning home from our NVRG picnic. He was left stranded because a clutch clevis pin sheared, and he was unable to shift gears!



The clutch clevis (7532) is attached to the clutch shaft (7503) with a pin (73931) and the clutch pedal release lever (7532) is attached to the clutch pedal with a pin (7533) with a groove to hold the release spring.

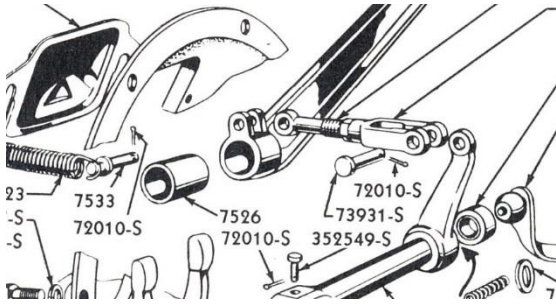

Both of these pins are not lubricated and wear to the point of shearing. See example of clevis pin taken from a '47 Mercury discovered when I replaced the clutch.



So, if you have not had clutch work done, or are unsure of the condition, it might be wise to check what shape these pins are in. A large amount of play in the adjusting rod might be an indication. And, this might be a good part to have as a spare. It is possible to do a roadside repair.

Sylvia was born in Kirkwall, Orkney Islands, U.K. In the early 1950s she immigrated with her family to Canada. While attending the University of Saskatchewan Nursing College she met and married Bill. After she graduated they immigrated to the U.S. where she had a successful career as a practicing nurse and then as a Clinical Research Associate supervising clinical drug trials.

Bill and Sylvia joined the Northern Virginia Regional Group in 1983 when they moved to the NoVa area from Nebraska. They were active participants in NVRG activities until moving to Ohio. They continued as remote NVRG members while in Ohio and later when they moved to Chesterfield. In 2012 Bill and Sylvia joined us at Graves Mountain Lodge for our annual Fall tour. Sylvia was a loving wife, devoted mother, aunt, grandmother and part of a strong, loving and supportive contingent of Canadian cousins. Sylvia's greatest passions were travelling, tending her flower garden and the camaraderie she found singing in show choirs. She always displayed a quick wit as she loved to banter, but always did so in an upbeat and positive manner. In lieu of flowers a memorial contribution can be made to the charity of your choice or to the Susan G. Komen Breast Cancer Awareness Association.

IN MEMORIAM



Sylvia Tindall

Sylvia Tindall (RN) of Chesterfield, passed away on Saturday, December 16, 2017. She is survived by Bill Tindall, her devoted husband of 50 years; two daughters, Christine Tindall and Laura Taylor; son-in-law, Michael Taylor; three grandchildren and numerous other relatives.

Bill Simons and Helen and Ken Burns attended the Celebration of Life for Sylvia on Friday December 29th. Several other members of the NVRG wanted to attend but were unable to due to health issues or previous commitments. Other V-8 friends, from the Richmond area, in attendance were Dick and Joan Rial and Tyree Harris.



NOTE: The "Automart" is now being maintained and updated by NVRG member Jim McDaniel. If you have any submissions, updates, or corrections, please contact Jim at jim44mcd@gmail.com (e-mail preferred) or cell: 202-409-4459. To be included in the next issue, new or changed ads need to be submitted to Jim by the **fourth Tuesday** of each month. Photos are acceptable for ads and will be included as space permits.

Vehicles FOR SALE



Early 1947 Super Deluxe Ford Coupe. Dark blue, 2017 Dearborn Award winner. Car located in Virginia. Bill Selley, 703-679-9462 (09/17)



1950 Ford V-8 Pilot Sedan. Less than 100 miles on body-off total restoration by meticulous engineer. 21 stud engine, 3 speed column shift, Right-hand-drive, factory front hydraulic brakes and dual exhaust with custom made stainless mufflers. NOS Grille, Marchal Headlamps, Leather upholstery, heater, radio (not working) handbook, built-in jacking system, parts book, shop manual and tool kit.

The basic body and mechanics are that of a 1935/6 USA V8. Current UK documents. Car is in London, England. I can assist with shipping. \$27,500 Colin Spong 1937lincoln@talktalk.net (08/17)



1936 FORD 5 Window Coupe. Same owner past 55 years; last 20 in covered, dry storage. 21 stud LB engine rebuilt in 1985. Extra running '36 engine. \$26,000 OBO. Located in PA. Mike Gall 814-619-8193 (11/16)



1953 Lincoln Capri Convertible and Coupe. Call for more info. Mike Gall 814-619-8193 (11/16)



Antique Farmall Cub Tractor. Includes the following implements: Belly Mower; Single Blade Moldboard Plow; Front Snowplow; Sickle bar mower. Has working hydraulic lift and PTO. Runs nice – needs paint & tires. Would make a great tractor for

parades, etc. The implements need to be cleaned and serviced in order to make them operable. Asking \$1,950 – contact me for more info. **Al Edwards** Front Royal, VA, 703-408-8372, Al-FromVA@aol.com (11/16)



Parts & Accessories FOR SALE



1948-1951 Ford F1 truck bench seat for sale. Upholstery is not stock, but is in very good condition. Asking \$150. Call Gay Harrington 703-888-0180.



36-39 Ford Complete Transmission – Completely rebuilt trans plus a nice top. All new (NOS Ford) internal parts (gears, shafts, bearings, etc.) and clutch release parts (shaft, fork and arm). Late 36 style gearset (all helical gears, 16 spline helical mainshaft for sliding gear) in a late pickup case (1946 top loader). Includes an excellent used 36 – 38 top. Will sell complete gearset without the case (i.e. if you want to install these gears in your case). Will not sell internal parts individually. **John Ryan**, 301-469-7328, john@ryanweb.com. (11/17)



Eastern National Meet Goodies – **Craftsman Tool Bag** - \$5.00, **Meet Gearshift Knob** - \$5.00; **Meet License Plate Topper** - \$5.00; **Compact LED Flashlight w/Clip & Magnet** - \$5.00; **Meet Pin** - \$1.00 or free w/purchase of one or more other item(s). **Hank Dubois** handcdubois@verizon.net or 703-476-6919 (07/17)



Shocks, 39-48 Ford – Original shocks with arms: R&L for 39-40 Rear (with dogbones). R&L for 41-48 Front. Used shocks that seem to be in good working

order. **John Ryan**, john@ryanweb.com 301-469-7328 (08/17)



Pair of 1949-51 three-rib fender skirts. Very good condition. Painted gloss black and was on my '51 until mid-1990s. \$100 for set. // **1949-50 chrome fog light set.** Reproduction. Never installed or used. New condition, no blemishes. Includes set of clear and amber 6-V sealed beam fog lights, wiring, switch and bracket, and instructions. \$100. // **"Universal" Turn Signal & Hazard Warning Switch.** Chrome, heavy duty, 7-wire harness, 2 green pilot lights for turn, 1 red pilot light for hazard. In-line fuse and installation instructions. Bought for my '52 F-1. New in Box, never installed. \$20. Photos of all items upon request. **Jim McDaniel**, jim44mcd@gmail.com c:202-409-4459 (8/16)



49-53 Ford & Mercury Engine Parts: Nearly all parts available: Heads, manifolds, crankshafts, rods, camshafts & valve parts, oil pans & oil filter housings, front covers, water pumps, bellhousings, ignition, etc. No Mercury crankshafts or oil pans. Dirt cheap! **John Ryan**, 301-469-7328, john@ryanweb.com (07/16)



Red's Flathead Engine Stand. **Steve Groves** – 301-530-7411 before 9:00 pm. (06/16)



Tools - 6 piece hand tool kit with pouch for your exact year/month EV-8, with "B" tip screwdriver, tire iron, jack, jack handle, grease gun, and pump optional with purchase, as available. **Dave Henderson**. jrdshen@verizon.net or 703-938-8954 (02/16)



1934 Parts: 40 year collection. 3x21 stud motors; 1 re-cored 33-34 radiator (never used); many 33-39 transmission gears (some NOS); 1 complete 33-35 transmission ready to use; 34 block motor mounts, door locks and ignition parts; generators; starters; water pumps; carbs; 34 oil pan; intake and exhaust

manifolds; steel cylinder heads; NOS cams; new valves; crankshaft pulleys; 34 steering gear rebuild kit with new shaft and bearings; 34 and 40 brake drums and backing plates; 34 and 40 spindles; distributor parts; many small rubber and metal parts; 34 Ford bolt collection for rebuilding a car. **Don Hill** 1308 Bragg Road, Fredericksburg, VA 22407 – 540-847-3363 (updated 06/16)



Vehicles WANTED

Driver quality 35-36 Pickup wanted: Contact Nick Arrington, nta1153@verizon.net or 703-966-8422 (01/15)



Parts & Accessories WANTED

1952 Ford Pickup Body. F-1, F-2 or F-3. Body can be rough but with a good frame (roller). Must have a good VA title and VIN plate. Ray Lambert 703-595-9834. (08/17)



1937 Ford. Right front fender. **Norm Heathcoat**, vvomllc@hotmail.com or 410-227-2040 (6/17)



Model A Pickup Bed: Any leads appreciated. Contact Nick Arrington – nta1153@verizon.net or 703-966-8422 (02/17)



Inside Window Molding for 1934 Ford 5 Window Coupe – **Ray Lambert** 703-595-9834 (12/16)



DC 1932 license plate. Any condition. Looking for a "wall hanger" to complete a mine project for my wall. **Jim Rodda**. jrodda1932@gmail.com (8/16)



For 1940 Ford – split core 1940 Ford radiator – **Bill Chaney**, flihi@cablefirst.net or 804-776-7597 (12/14)



'40 Ford Oil Bath Air Filter – Thanks in advance. **Nick Arrington**, nta1153@verizon.net or 703-966-8422 (01/16)



For 1940 Ford – heater switch for hot water heater. – **Bill Chaney**, flihi@cablefirst.net or 804-776-7597 (12/14)



For 1935 Ford closed car: the radio speaker with cable and connector to the radio box. **Jim Eberly** – 301-689-9420 – Jeberly4@comcast.net (07/14)





NVRG Calendar



<u>January 2018</u>	
1	HAPPY NEW YEAR!
9	Membership Meeting – 7:00 pm – Nottaway Park – Program: <i>Only Yesterday Museum</i> in San Diego by Ken Burns – Refreshments: John Sweet
30	NVRG Board of Directors Meeting – Red Hot and Blue, City of Fairfax. Dinner at 6:30; meeting at 7:30. All welcome to attend.
30	Valve Clatter Deadline - submit articles, want/sell, etc.
<u>February 2018</u>	
13	Caffeine Double Clutch Breakfast – Fair Oaks Silver Diner at 9:30 AM. Questions? Contact Ken Burns helenandken@verizon.net or Clem Clement clem.clement@cox.net .
14	Membership Meeting – 7:00 pm – Nottaway Park – Program: How the Model A Won WWII – Refreshments: Clem Clement
27	NVRG Board of Directors Meeting – Red Hot and Blue, City of Fairfax. Dinner at 6:30; meeting at 7:30. All welcome to attend.
27	Valve Clatter Deadline - submit articles, want/sell, etc.
<u>March 2018</u>	
13	Membership Meeting – 7:00 pm – Nottaway Park – Program: TBD – Refreshments: Nick Arrington
14	Caffeine Double Clutch Breakfast – Fair Oaks Silver Diner at 9:30 AM. Questions? Contact Ken Burns helenandken@verizon.net or Clem Clement clem.clement@cox.net
27	NVRG Board of Directors Meeting – Red Hot and Blue, City of Fairfax. Dinner at 6:30; meeting at 7:30. All welcome to attend.
28	Valve Clatter Deadline - submit articles, want/sell, etc.

2 DAYS
FRIDAY & SATURDAY

SUGARLOAF MOUNTAIN REGION AACAA

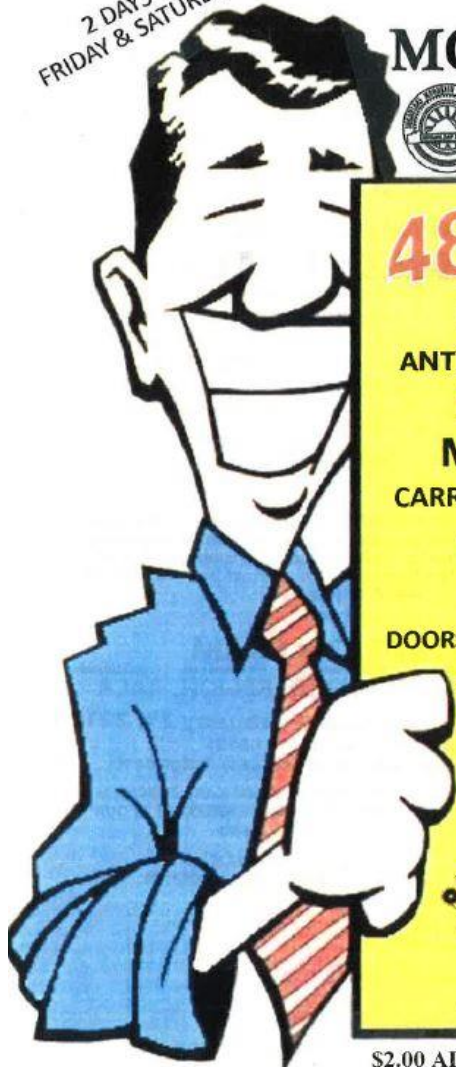

48th ANNUAL

INDOOR/OUTDOOR

ANTIQUÉ AUTO * TRUCK * MOTORCYCLE

PARTS / SWAP MEET

MARCH 23 & 24, 2018

CARROLL COUNTY AGRICULTURE CENTER

706 AGRICULTURE CENTER DRIVE

WESTMINSTER, MD 21157

info@carrollcountyagcenter.com

Call (301) 674-5431 for details

DOORS OPEN: 8:00am FRIDAY & SATURDAY

52,500 SQ FT ALL HEATED BUILDING

HUNDREDS OF VENDOR SPACES

INDOOR

OUTDOOR

CAR CORRAL



FREE

ABUNDANT PARKING

\$2.00 ADMISSION - CHILDREN 10 & UNDER FREE

CONTACT: JACK GALLAGHER (301)674-5431, EMAIL smraaca@aol.com

BUY - SELL - SWAP - LEARN

ADDITIONAL SPACE
RESERVED AS NEEDED

SEE REVERSE SIDE FOR REGISTRATION FORM

CAR CORRAL * 50-50 DRAWINGS * MEMBERSHIP AVAILABILITY

See next page for registration details.

HOW DO I GET THERE ?? FOR DIRECTIONS GO TO
www.carrollcountygacenter.com/directions



"SOMETHING FOR ALL AUTO ENTHUSIASTS"



BIGGEST INDOOR AND OUTDOOR ANTIQUE AUTO PARTS MEET IN THE AREA

One Large Heated Enclosed Building – Over 52,000 sqft

Early Bird Prices **BEFORE FEBRUARY 21, 2018******

**** Post Marked or Credit Card Received

Indoor Flea Market spaces of Approximately 100 sqft @ **\$45.00 Each**

Outdoor Spaces Approximately 200 sqft @ **\$60.00 Each**

Slightly Larger Outdoor Spaces @ **\$70.00 Each**

Each Car **Corral Space @ 45.00** per vehicle for both days.

■ Cars, Trucks, Motorcycles, Trailers –

NO SELLING of any Flea Market Items in the Car Corral Area

Ask any **SUGARLOAF MOUNTAIN REGION** member at the meet how you can join our region. Lots of activities, fun, & knowledge of all older autos & trucks. SMR members & their spouses are located throughout Maryland & Virginia. Must be a member of AACA to join.

PRE-REGISTRATION FORM

Please make checks payable to: **SUGARLOAF MOUNTAIN REGION, AACA**

Mail To: Jack Gallagher
 6209 Redwing Court
 Bethesda, Maryland 20817

Return Vendor Registration Deadline **February 21, 2018**

Questions: Call: **301-674-5431**

On-Site: See Registration Desk For Space Assignments

Vendor Name: _____
 Address: _____
 City: _____ State: _____ Zip: _____
 Phone: () _____ Cell: () _____

ALL MAKE & MODEL CARS, TRUCKS, & MOTORCYCLES ARE WELCOME AT OUR SHOW

ALL MAJOR CREDIT CARDS ACCEPTED

VERY IMPORTANT - E-MAIL

Quantity On or Before 02/21/2018	Quantity On or After 02/22/2018	Space Pricing	Total
		Indoor Spaces \$45 Before 02/21/2018 - \$50. After Both Days	
		Outdoor Spaces \$60 Before 02/21/2018 - \$65. After Both Days	
		Car Corral Space \$45 Before 02/21/2018 - \$50. After Both Days	
		Rentals: Per Chair \$2.00 Before 02/21/2018 - \$4.00 After Both Days	
		Per Table \$5.00 Before 02/21/2018 - \$10.00 After Both Days	
		Total Due	
		SORRY – NO REFUNDS AND NO RV-HOOK-UP	

THANK YOU FOR YOUR SUPPORT

\$2.00 ADMISSION – CHILDREN 10 & UNDER FREE

NVRG Car of the Month
Pat O'Neill's 1937 Pickup



FIRST CLASS MAIL